

Timing Pulleys

HTD 同步帶輪 3M. 5M. 8M. 14M. 20M

STD 同步帶輪 S3M. S5M. S8M. S14M

RPP 同步帶輪 P3M. P5M. P8M. P14M. P20M

T形齒同步帶輪 T2.5. T5. T10. T20

AT形齒同步帶輪 AT3. AT5. AT10. AT20

英制同步帶輪 MXL. XL. L. H. XH



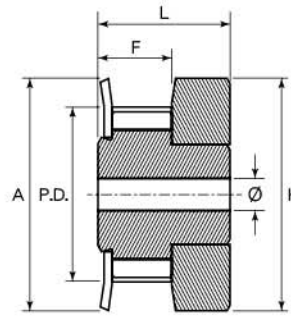
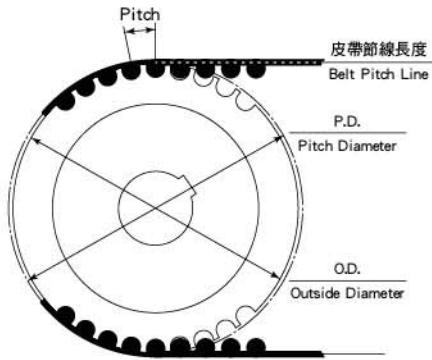

Type 1F

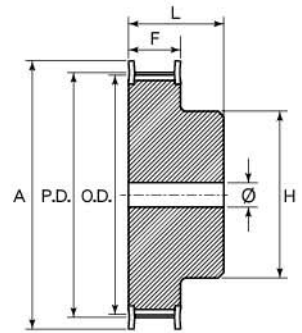

Type 2F

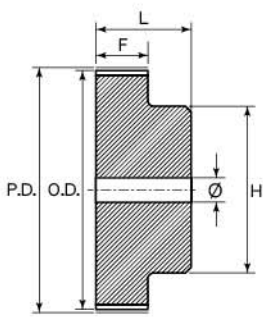

Type 3

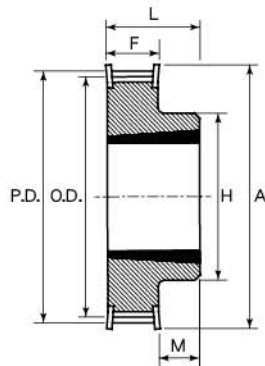

Type 4F

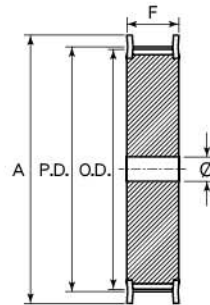

Type 5F

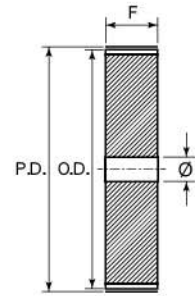

Type 6

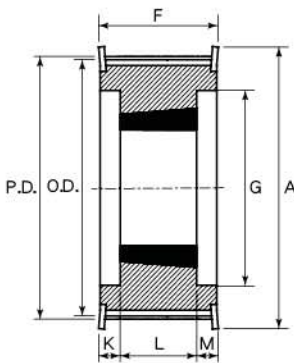

Type 7F

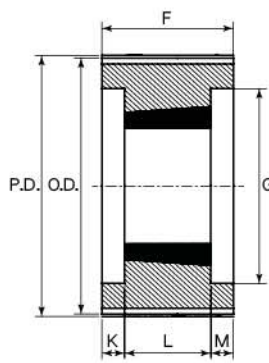

Type 8

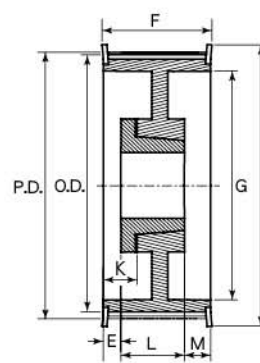

Type 9F

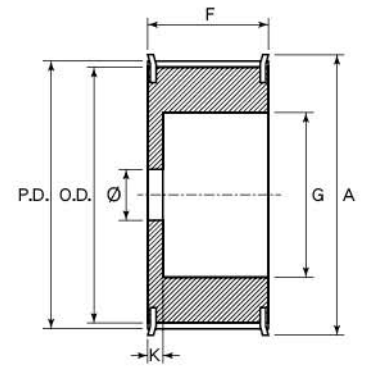

Type 10F

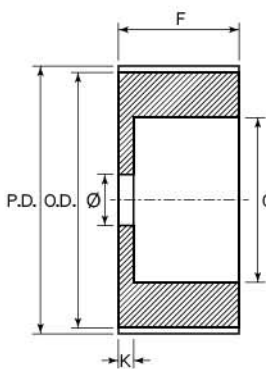

Type 11

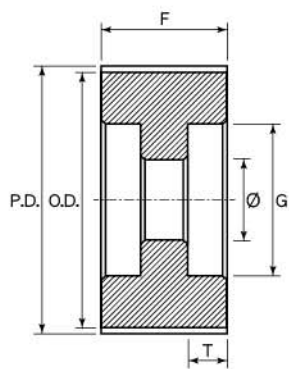

Type 12

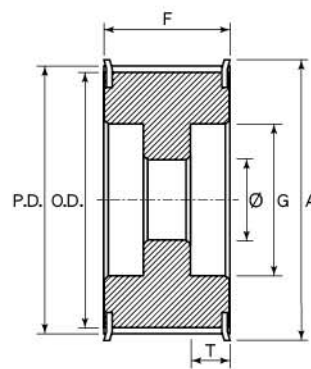

Type 13F

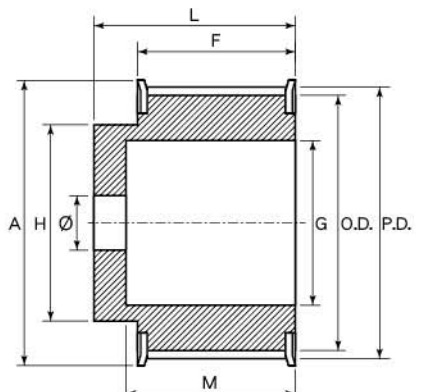

Type 14F

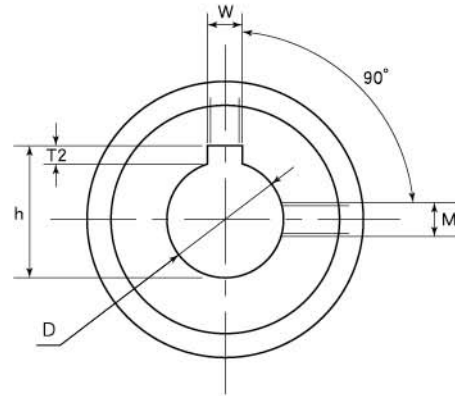
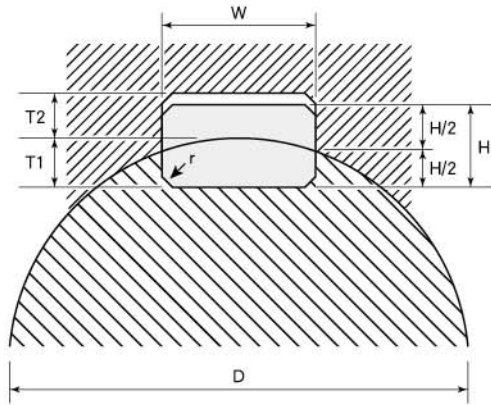

ISO Standard—mm W×H = Key 鍵 W×T2 = Keyway 鍵槽

Shaft Diameter		W	H	T1	T2
D					
>	≦				
6	8	2	2	1.2	1
8	10	3	3	1.8	1.4
10	12	4	4	2.5	1.8
12	17	5	5	3.0	2.3
17	22	6	6	3.5	2.8
22	30	8	7	4.0	3.3
30	38	10	8	5.0	3.3
38	44	12	8	5.0	3.3
44	50	14	9	5.5	3.8
50	58	16	10	6.0	4.3
58	65	18	11	7.0	4.4
65	75	20	12	7.5	4.9
75	85	22	14	9.0	5.4
85	95	25	14	9.0	5.4
95	110	28	16	10.0	6.4
110	130	32	18	11.0	7.4
130	150	36	20	12.0	8.4
150	170	40	22	13.0	9.4

JIS Standard—mm M=SET SCREW 緊定螺絲

Bore Diameter		Key	T2	M
D				
>	≦			
10	12	4×4	1.8	M6
12	17	5×5	2.3	M6
17	22	6×6	2.8	M6
20	25	(7×7)	3.0	M6
22	30	8×7	3.3	M8
30	38	10×8	3.3	M8
38	44	12×8	3.3	M8
44	50	14×9	3.8	M10
50	55	(15×10)	5.0	M10
50	58	16×10	4.3	M10
58	65	18×11	4.4	M10
65	75	20×12	4.9	M12
75	85	22×14	5.4	M12
80	90	(24×16)	8.0	M12
85	95	25×14	5.4	M12
95	110	28×16	6.4	M12
110	130	32×18	7.4	M12
125	140	(35×22)	11.0	M12



二進一出 (1008-3030)



三進二出 (3525-6050)

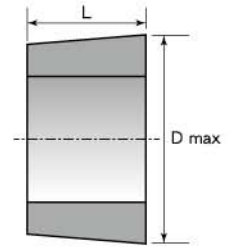

mm

錐套規格 Bush Size			1008	1108	1210	1610	1615	2012	2517	3020	3030
外徑	D	mm	35.0	38.0	47.5	57.0	57.0	70.0	85.5	108.0	108.0
長度	L	mm	22.3	22.3	25.4	25.4	38.1	31.8	44.5	50.8	76.2
螺絲	screw	inches	1/4 x 1/2	1/4 x 1/2	5/8 x 5/8	5/8 x 5/8	5/8 x 5/8	7/16 x 7/8	1/2 x 1	5/8 x 1 1/4	5/8 x 1 1/8
板手	wrench	No	3	3	5	5	5	6	6	8	8
扭矩	torque	Nm	5.7	5.7	20	20	20	31	49	92	92
重量	weight	kg	0.12	0.16	0.28	0.42	0.61	0.75	1.1	2.61	3.8
孔徑	bore	mm	09-25	09-28	11-32	14-42	14-42	14-50	16-60	25-75	35-75

mm

錐套規格 Bush Size			3525	3535	4030	4040	4535	4545	5040	5050	6050
外徑	D	mm	127.0	127.0	146.0	146.0	162.0	162.0	177.5	177.5	235.0
長度	L	mm	63.5	88.9	76.2	101.6	88.9	114.3	101.6	127.0	127.0
螺絲	screw	inches	1/2 x 1 1/2	1/2 x 1 1/2	5/8 x 1 3/4	5/8 x 1 3/4	3/4 x 2	3/4 x 2	7/8 x 2 1/4	7/8 x 2 1/4	7/8 x 2 1/4
板手	wrench	No	10	10	12	12	14	14	14	14	14
扭矩	torque	Nm	115	115	172	172	195	195	275	275	275
重量	weight	kg	3.9	5.25	7.1	7.8	11.8	12.8	14.2	15.3	27
孔徑	bore	mm	35-100	35-90	40-115	40-100	55-125	55-110	70-125	70-125	95-150

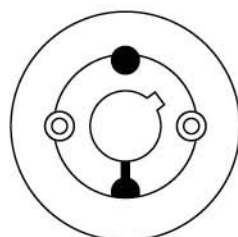

◎：安裝螺孔

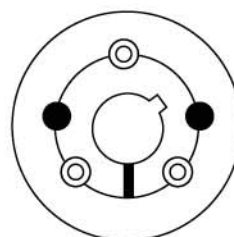

●：拆卸螺孔

規格 Specification – MXL

mm

Type	P		A	B	C	T	R1	R2
	mm	in						
MXL	2.032	2/25"	40°	1.1	0.45	1.24	0.13	0.13
XL	5.08	1/5"	50°	2.3	1.22	2.57	0.38	0.38
L	9.525	3/8"	40°	3.6	1.85	4.65	0.51	0.51
H	12.7	1/2"	40°	3.9	2.18	6.12	1.02	1.02
XH	22.225	7/8"	40°	4.0	6.22	12.57	1.19	1.57

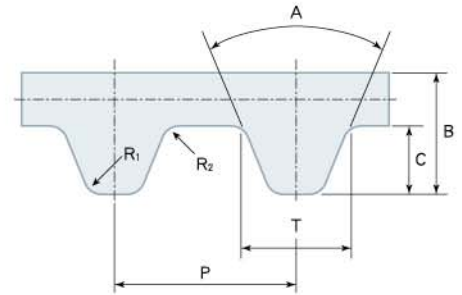

Z	OD	PD
10	5.96	6.47
11	6.61	7.12
12	7.25	7.76
13	7.90	8.41
14	8.55	9.06
15	9.19	9.70
16	9.84	10.35
17	10.49	11.00
18	11.13	11.64
19	11.78	12.29
20	12.43	12.94
21	13.07	13.58
22	13.72	14.23
23	14.37	14.88
24	15.01	15.52
25	15.66	16.17
26	16.31	16.82
27	16.95	17.46
28	17.60	18.11
29	18.25	18.76
30	18.89	19.40
31	19.54	20.05
32	20.19	20.70
33	20.83	21.34
34	21.48	21.99
35	22.13	22.64
36	22.78	23.29
37	23.42	23.93
38	24.07	24.58
39	24.72	25.23
40	25.36	25.87
41	26.01	26.52
42	26.66	27.17
43	27.30	27.81

Z	OD	PD
44	27.95	28.46
45	28.60	29.11
46	29.24	29.75
47	29.89	30.40
48	30.54	31.05
49	31.18	31.69
50	31.83	32.34
51	32.48	32.99
52	33.12	33.63
53	33.77	34.28
54	34.42	34.93
55	35.06	35.57
56	35.71	36.22
57	36.36	36.87
58	37.00	37.51
59	37.65	38.16
60	38.30	38.81
61	38.95	39.46
62	39.59	40.10
63	40.24	40.75
64	40.89	41.40
65	41.53	42.04
66	42.18	42.69
67	42.83	43.34
68	43.47	43.98
69	44.12	44.63
70	44.77	45.28
71	45.41	45.92
72	46.06	46.57
73	46.71	47.22
74	47.35	47.86
75	48.00	48.51
76	48.65	49.16
77	49.29	49.80

Z	OD	PD
78	49.94	50.45
79	50.59	51.10
80	51.23	51.74
81	51.88	52.39
82	52.53	53.04
83	53.17	53.68
84	53.82	54.33
85	54.47	54.98
86	55.12	55.63
87	55.76	56.27
88	56.41	56.92
89	57.06	57.57
90	57.70	58.21
91	58.36	58.86
92	59.00	59.51
93	59.64	60.15
94	60.29	60.80
95	60.94	61.45
96	61.58	62.09
97	62.23	62.74
98	62.88	63.39
99	63.52	64.03
100	64.17	64.68
101	64.82	65.33
102	65.46	65.97
103	66.11	66.62
104	66.76	67.27
105	67.40	67.91
106	68.05	68.56
107	68.70	69.21
108	69.34	69.85
109	69.99	70.50
110	70.64	71.15
111	71.29	71.80

Z	OD	PD
112	71.93	72.44
113	72.58	73.09
114	73.23	73.74
115	73.87	74.38
116	74.52	75.03
117	75.17	75.68
118	75.81	76.32
119	76.46	76.97
120	77.11	77.62
121	77.75	78.26
122	78.40	78.91
123	79.05	79.56
124	79.69	80.20
125	80.34	80.85
126	80.99	81.50
127	81.63	82.14
128	82.28	82.79
129	82.93	83.44
130	83.57	84.08
131	84.22	84.73
132	84.87	85.38
133	85.51	86.02
134	86.16	86.67
135	86.81	87.32
136	87.46	87.97
137	88.10	88.61
138	88.75	89.26
139	89.40	89.91
140	90.04	90.55
142	91.34	91.85
143	91.99	92.49
145	93.28	93.79
148	95.22	95.73
150	96.51	97.02

MXL Inch Pitch-Type

規格 Specification – XL

mm

Type	P		A	B	C	T	R1	R2
	mm	in						
MXL	2.032	2/25 "	40°	1.1	0.45	1.24	0.13	0.13
XL	5.08	1/5 "	50°	2.3	1.22	2.57	0.38	0.38
L	9.525	3/8 "	40°	3.6	1.85	4.65	0.51	0.51
H	12.7	1/2 "	40°	3.9	2.18	6.12	1.02	1.02
XH	22.225	7/8 "	40°	4.0	6.22	12.57	1.19	1.57

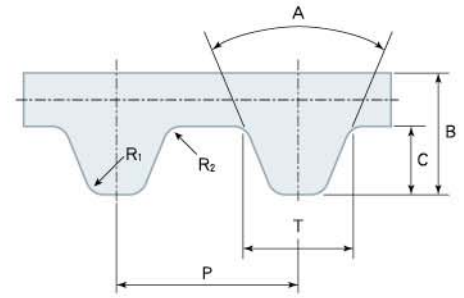

Z	OD	PD
10	15.66	16.17
11	17.28	17.79
12	18.89	19.40
13	20.51	21.02
14	22.13	22.64
15	23.74	24.25
16	25.36	25.87
17	26.98	27.49
18	28.60	29.11
19	30.21	30.72
20	31.83	32.34
21	33.45	33.96
22	35.06	35.57
23	36.68	37.19
24	38.30	38.81
25	39.92	40.43
26	41.53	42.04
27	43.15	43.66
28	44.77	45.28
29	46.38	46.89
30	48.00	48.51
31	49.62	50.13
32	51.23	51.74
33	52.85	53.36
34	54.47	54.98
35	56.09	56.60
36	57.70	58.21
37	59.32	59.83

Z	OD	PD
38	60.94	61.45
39	62.55	63.06
40	64.17	64.68
41	65.79	66.30
42	67.40	67.91
43	69.02	69.53
44	70.64	71.15
45	72.26	72.77
46	73.87	74.38
47	75.49	76.00
48	77.11	77.62
49	78.72	79.23
50	80.34	80.85
51	81.96	82.47
52	83.57	84.08
53	85.19	85.70
54	86.81	87.32
55	88.42	88.93
56	90.04	90.55
57	91.66	92.17
58	93.28	93.79
59	94.89	95.40
60	96.51	97.02
61	98.13	98.64
62	99.74	100.25
63	101.36	101.87
64	102.98	103.49
65	104.60	105.11

Z	OD	PD
66	106.21	106.72
67	107.83	108.34
68	109.45	109.96
69	111.06	111.57
70	112.68	113.19
71	114.30	114.81
72	115.92	116.43
73	117.53	118.04
74	119.15	119.66
75	120.77	121.28
76	122.38	122.89
77	124.00	124.51
78	125.62	126.13
79	127.23	127.74
80	128.85	129.36
81	130.47	130.98
82	132.08	132.59
83	133.70	134.21
84	135.32	135.83
85	136.93	137.44
86	138.55	139.06
87	140.17	140.68
88	141.79	142.30
89	143.41	143.91
90	145.02	145.53
91	146.64	147.15
92	148.25	148.76
93	149.87	150.38

Z	OD	PD
94	151.49	152.00
95	153.11	153.62
96	154.72	155.23
97	156.34	156.85
98	157.96	158.47
99	159.57	160.08
100	161.19	161.70
101	162.81	163.32
102	164.42	164.93
103	166.04	166.55
104	167.66	168.17
105	169.28	169.79
106	170.89	171.40
107	172.51	173.02
108	174.13	174.64
109	175.74	176.25
110	177.36	177.87
111	178.98	179.49
112	180.59	181.10
113	182.21	182.72
114	183.83	184.34
115	185.44	185.95
116	187.06	187.57
117	188.68	189.19
118	190.30	190.81
119	191.91	192.42
120	193.53	194.04

XL Inch Pitch-Type

規格 Specification – L

mm

Type	P		A	B	C	T	R1	R2
	mm	in						
MXL	2.032	2/25"	40°	1.1	0.45	1.24	0.13	0.13
XL	5.08	1/5"	50°	2.3	1.22	2.57	0.38	0.38
L	9.525	3/8"	40°	3.6	1.85	4.65	0.51	0.51
H	12.7	1/2"	40°	3.9	2.18	6.12	1.02	1.02
XH	22.225	7/8"	40°	4.0	6.22	12.57	1.19	1.57

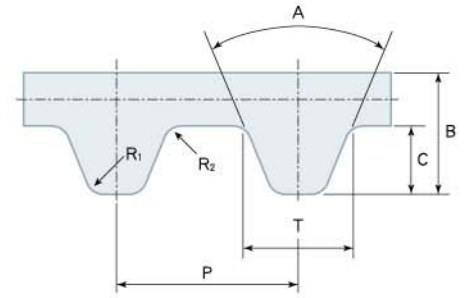

Z	OD	PD
10	29.56	30.32
11	32.59	33.35
12	35.62	36.38
13	38.65	39.41
14	41.68	42.44
15	44.71	45.47
16	47.74	48.50
17	50.77	51.53
18	53.80	54.56
19	56.83	57.61
20	59.88	60.64
21	62.91	63.67
22	65.94	66.70
23	68.97	69.73
24	72.00	72.76
25	75.03	75.80
26	78.06	78.83
27	81.09	81.86
28	84.12	84.89
29	87.15	87.92
30	90.20	90.95
31	93.23	93.98
32	96.26	97.01
33	99.29	100.04
34	102.32	103.07
35	105.35	106.12
36	108.38	109.15
37	111.41	112.18

Z	OD	PD
38	114.44	115.21
39	117.47	118.24
40	120.52	121.27
41	123.55	124.30
42	126.58	127.33
43	129.61	130.36
44	132.64	133.39
45	135.67	136.44
46	138.70	139.47
47	141.73	142.50
48	144.76	145.53
49	147.80	148.56
50	150.83	151.59
51	153.86	154.62
52	156.89	157.65
53	159.92	160.68
54	162.95	163.71
55	166.00	166.76
56	169.03	169.79
57	172.06	172.82
58	175.09	175.85
59	178.12	178.88
60	181.15	181.91
61	184.18	184.94
62	187.21	187.97
63	190.24	191.00
64	193.27	194.03
65	196.30	197.06

Z	OD	PD
66	199.33	200.11
67	202.38	203.14
68	205.41	206.17
69	208.44	209.20
70	211.47	212.23
71	214.50	215.26
72	217.53	218.29
73	220.56	221.32
74	223.59	224.35
75	226.62	227.38
76	229.65	230.41
77	232.70	233.46
78	235.73	236.49
79	238.76	239.52
80	241.79	242.55
81	244.82	245.58
82	247.85	248.61
83	250.88	251.64
84	253.91	254.67
85	256.94	257.70
86	259.97	260.73
87	263.02	263.78
88	266.05	266.81
89	269.08	269.84
90	272.11	272.87
91	275.14	275.90
92	278.17	278.93
93	281.20	281.96

Z	OD	PD
94	284.23	285.00
95	287.26	288.03
96	290.30	291.06
97	293.33	294.09
98	296.36	297.12
99	299.40	300.15
100	302.43	303.18
101	305.46	306.21
102	308.49	309.24
103	311.52	312.29
104	314.55	315.32
105	317.58	318.35
106	320.61	321.38
107	323.64	324.41
108	326.69	327.44
109	329.72	330.47
110	332.75	333.50
111	335.78	336.53
112	338.81	339.56
113	341.84	342.61
114	344.87	345.64
115	347.90	348.67
116	350.93	351.70
117	353.96	354.73
118	357.00	357.76
119	360.03	360.79
120	363.07	363.82

L Inch Pitch-Type

規格 Specification – H

mm

Type	P		A	B	C	T	R1	R2
	mm	in						
MXL	2.032	2/25"	40°	1.1	0.45	1.24	0.13	0.13
XL	5.08	1/5"	50°	2.3	1.22	2.57	0.38	0.38
L	9.525	3/8"	40°	3.6	1.85	4.65	0.51	0.51
H	12.7	1/2"	40°	3.9	2.18	6.12	1.02	1.02
XH	22.225	7/8"	40°	4.0	6.22	12.57	1.19	1.57

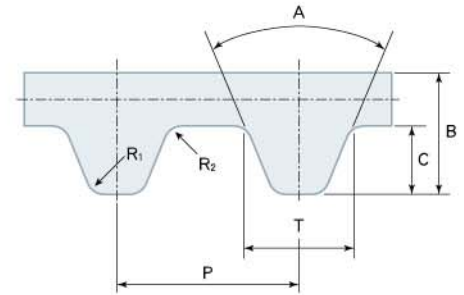

Z	OD	PD
14	55.23	56.60
15	59.27	60.64
16	63.31	64.68
17	67.35	68.72
18	71.40	72.76
19	75.44	76.80
20	79.48	80.84
21	83.52	84.88
22	87.57	88.94
23	91.61	92.98
24	95.65	97.02
25	99.69	101.06
26	103.73	105.10
27	107.77	109.14
28	111.81	113.18
29	115.85	117.22
30	119.91	121.28
31	123.95	125.32
32	127.99	129.36
33	132.03	133.40
34	136.07	137.44
35	140.11	141.48
36	144.15	145.52
37	148.20	149.56
38	152.24	153.62
39	156.28	157.66
40	160.32	161.70
41	164.36	165.74

Z	OD	PD
42	168.42	169.78
43	172.46	173.82
44	176.50	177.86
45	180.54	181.90
46	184.58	185.96
47	188.62	190.00
48	192.67	194.04
49	196.71	198.08
50	200.75	202.13
51	204.80	206.17
52	208.84	210.21
53	212.88	214.25
54	216.92	218.29
55	220.96	222.33
56	225.00	226.37
57	229.04	230.41
58	233.10	234.47
59	237.14	238.51
60	241.18	242.55
61	245.22	246.59
62	249.26	250.63
63	253.30	254.67
64	257.34	258.71
65	261.38	262.75
66	265.44	266.81
67	269.48	270.85
68	273.52	274.89
69	277.56	278.93

Z	OD	PD
70	281.60	282.97
71	285.64	287.01
72	289.68	291.05
73	293.72	295.10
74	297.78	299.14
75	301.82	303.18
76	305.86	307.22
77	309.90	311.26
78	313.94	315.32
79	317.98	319.36
80	322.02	323.40
81	326.06	327.44
82	330.12	331.48
83	334.16	335.52
84	338.20	339.56
85	342.24	343.60
86	346.28	347.66
87	350.33	351.70
88	354.37	355.74
89	358.41	359.78
90	362.45	363.82
91	366.50	367.86
92	370.54	371.90
93	374.58	375.94
94	378.62	380.00
95	382.66	384.04
96	386.70	388.08
97	390.74	392.12

Z	OD	PD
98	394.80	396.16
99	398.84	400.20
100	402.88	404.24
101	406.92	408.28
102	410.96	412.34
103	415.00	416.38
104	419.04	420.42
105	423.08	424.46
106	427.14	428.50
107	431.18	432.54
108	435.22	436.58
109	439.26	440.62
110	443.30	444.68
111	447.34	448.72
112	451.38	452.76
113	455.42	456.80
114	459.48	460.84
115	463.52	464.88
116	467.56	468.92
117	471.60	472.96
118	475.64	477.02
119	479.68	481.06
120	483.72	485.10

H Inch Pitch-Type

規格 Specification – XH

mm

Type	P		A	B	C	T	R1	R2
	mm	in						
MXL	2.032	2/25"	40°	1.1	0.45	1.24	0.13	0.13
XL	5.08	1/5"	50°	2.3	1.22	2.57	0.38	0.38
L	9.525	3/8"	40°	3.6	1.85	4.65	0.51	0.51
H	12.7	1/2"	40°	3.9	2.18	6.12	1.02	1.02
XH	22.225	7/8"	40°	4.0	6.22	12.57	1.19	1.57

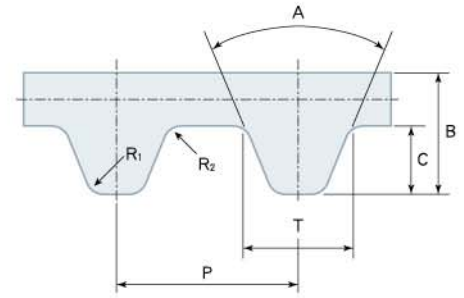

Z	OD	PD
18	124.55	127.34
19	131.62	134.41
20	138.68	141.48
21	145.76	148.55
22	152.84	155.64
23	159.91	162.71
24	167.00	169.78
25	174.07	176.85
26	181.13	183.94
27	188.20	191.01
28	195.27	198.08
29	202.37	205.15
30	209.44	212.22
31	216.51	219.31
32	223.58	226.38
33	230.66	233.45
34	237.73	240.52
35	244.80	247.59
36	251.87	254.68
37	258.94	261.75
38	266.02	268.82
39	273.11	275.89
40	280.18	282.98
41	287.25	290.05
42	294.33	297.12
43	301.40	304.19
44	308.47	311.26
45	315.54	318.35

Z	OD	PD
46	322.61	325.42
47	329.70	332.49
48	336.77	339.57
49	343.87	346.66
50	350.93	353.73
51	358.00	360.80
52	365.07	367.87
53	372.14	374.94
54	379.21	382.01
55	386.30	389.08
56	393.37	396.17
57	400.44	403.24
58	407.51	410.31
59	414.58	417.38
60	421.68	424.47
61	428.75	431.54
62	435.90	438.61
63	442.90	445.68
64	449.97	452.75
65	457.05	459.84
66	464.12	466.91
67	471.20	473.98
68	478.25	481.05
69	485.34	488.12
70	492.39	495.21
71	499.48	502.28
72	506.57	509.35
73	513.63	516.42

Z	OD	PD
74	520.70	523.51
75	527.79	530.58
76	534.84	537.65
77	541.93	544.72
78	549.00	551.79
79	556.07	558.88
80	563.15	565.95
81	570.22	573.02
82	577.29	580.09
83	584.36	587.18
84	591.43	594.25
85	598.60	601.32
86	605.61	608.39
87	612.68	615.46
88	619.75	622.55
89	626.82	629.62
90	633.91	636.69
91	640.96	643.76
92	648.04	650.85
93	655.13	657.92
94	662.20	664.99
95	669.28	672.06
96	676.35	679.15
97	683.43	686.22
98	690.50	693.29
99	697.58	700.36
100	704.65	707.43
101	711.70	714.50

Z	OD	PD
102	718.77	721.59
103	725.85	728.66
104	732.92	735.73
105	740.01	742.80
106	747.08	749.87
107	754.15	756.96
108	761.22	764.03
109	768.30	771.10
110	775.37	778.17
111	782.44	785.26
112	789.51	792.33
113	796.60	799.40
114	803.67	806.47
115	810.74	813.54
116	817.81	820.63
117	824.88	827.70
118	831.95	834.77
119	839.03	841.84
120	846.12	848.93

XH Inch Pitch-Type

規格 Specification – T2.5

mm

Type	P	A	B	C	W
T2.5	2.5	40°	1.3	0.7	1.0
T5	5	40°	2.3	1.2	1.8
T10	10	40°	4.5	2.5	3.5
T20	20	40°	8	5.0	6.5

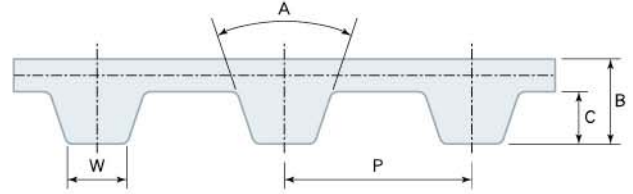

Z	OD	PD
10	7.46	7.96
11	8.25	8.75
12	9.05	9.55
13	9.85	10.35
14	10.64	11.14
15	11.44	11.94
16	12.23	12.73
17	13.03	13.53
18	13.82	14.32
19	14.62	15.12
20	15.42	15.92
21	16.21	16.71
22	17.01	17.51
23	17.80	18.30
24	18.60	19.10
25	19.39	19.89
26	20.19	20.69
27	20.99	21.49
28	21.78	22.28
29	22.58	23.08
30	23.37	23.87
31	24.17	24.67
32	24.97	25.47
33	25.76	26.26
34	26.56	27.06
35	27.35	27.85
36	28.15	28.65
37	28.94	29.44
38	29.74	30.24
39	30.54	31.04
40	31.33	31.83
41	32.13	32.63
42	32.92	33.42

Z	OD	PD
43	33.72	34.22
44	34.52	35.02
45	35.31	35.81
46	36.11	36.61
47	36.90	37.40
48	37.70	38.20
49	38.49	38.99
50	39.29	39.79
51	40.09	40.59
52	40.88	41.38
53	41.68	42.18
54	42.47	42.97
55	43.27	43.77
56	44.06	44.56
57	44.86	45.36
58	45.66	46.16
59	46.45	46.95
60	47.25	47.75
61	48.04	48.54
62	48.84	49.34
63	49.64	50.14
64	50.43	50.93
65	51.23	51.73
66	52.02	52.52
67	52.82	53.32
68	53.61	54.11
69	54.41	54.91
70	55.21	55.71
71	56.00	56.50
72	56.80	57.30
73	57.59	58.09
74	58.39	58.89
75	59.18	59.68

Z	OD	PD
76	59.98	60.48
77	60.78	61.28
78	61.57	62.07
79	62.37	62.87
80	63.16	63.66
81	63.96	64.46
82	64.76	65.26
83	65.55	66.05
84	66.35	66.85
85	67.14	67.64
86	67.94	68.44
87	68.73	69.23
88	69.53	70.03
89	70.33	70.83
90	71.12	71.62
91	71.92	72.42
92	72.71	73.21
93	73.51	74.01
94	74.31	74.81
95	75.10	75.60
96	75.90	76.40
97	76.69	77.19
98	77.49	77.99
99	78.28	78.78
100	79.08	79.58
101	79.88	80.38
102	80.67	81.17
103	81.47	81.97
104	82.26	82.76
105	83.06	83.56
106	83.85	84.35
107	84.65	85.15
108	85.45	85.95

Z	OD	PD
109	86.24	86.74
110	87.04	87.54
111	87.83	88.33
112	88.63	89.13
113	89.43	89.93
114	90.22	90.72
115	91.02	91.52
116	91.81	92.31
117	92.61	93.11
118	93.40	93.90
119	94.20	94.70
120	95.00	95.50
121	95.79	96.29
122	96.59	97.09
123	97.38	97.88
124	98.18	98.68
125	98.97	99.47
126	99.77	100.27
127	100.57	101.07
128	101.36	101.86
129	102.16	102.66
130	102.95	103.45
131	103.75	104.25
132	104.55	105.05
133	105.34	105.84
134	106.14	106.64
135	106.93	107.43
136	107.73	108.23
137	108.52	109.02
138	109.32	109.82
139	110.12	110.62
140	110.91	111.41

規格 Specification – T5

mm

Type	P	A	B	C	W
T2.5	2.5	40°	1.3	0.7	1.0
T5	5	40°	2.3	1.2	1.8
T10	10	40°	4.5	2.5	3.5
T20	20	40°	8	5.0	6.5

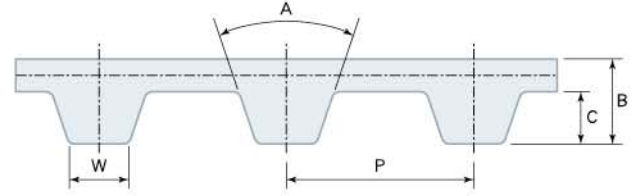

Z	OD	PD
10	15.05	15.92
11	16.65	17.51
12	18.25	19.10
13	19.85	20.70
14	21.45	22.29
15	23.05	23.88
16	24.60	25.47
17	26.20	27.06
18	27.80	28.65
19	29.40	30.25
20	31.00	31.83
21	32.70	33.43
22	34.25	35.02
23	35.85	36.62
24	37.40	38.21
25	39.00	39.80
26	40.60	41.39
27	42.20	42.98
28	43.75	44.58
29	45.35	46.17
30	46.95	47.76
31	48.55	49.35
32	50.10	50.94
33	51.70	52.54
34	53.25	54.13
35	54.85	55.72
36	56.45	57.31
37	58.05	58.90

Z	OD	PD
38	59.65	60.50
39	61.25	62.09
40	62.85	63.66
41	64.40	65.27
42	66.00	66.86
43	67.70	68.46
44	69.20	70.05
45	70.80	71.64
46	72.40	73.23
47	73.95	74.82
48	75.55	76.42
49	77.15	78.01
50	78.75	79.60
51	80.35	81.19
52	81.95	82.78
53	83.50	84.38
54	85.10	85.97
55	86.70	87.54
56	88.30	89.15
57	89.90	90.74
58	91.50	92.34
59	93.05	93.93
60	94.65	95.52
61	96.25	97.11
62	97.85	98.70
63	99.45	100.30
64	101.05	101.89
65	102.65	103.48

Z	OD	PD
66	104.20	105.07
67	105.80	106.66
68	107.40	108.26
69	109.00	109.85
70	110.60	111.44
71	112.20	113.03
72	113.75	114.62
73	115.35	116.22
74	116.95	117.81
75	118.55	119.40
76	120.15	120.99
77	121.75	122.58
78	123.30	124.18
79	124.90	125.77
80	126.50	127.36
81	128.10	128.95
82	129.70	130.54
83	131.30	132.14
84	132.85	133.73
85	134.45	135.32
86	136.05	136.91
87	137.65	138.50
88	139.25	140.10
89	140.85	141.69
90	142.45	143.28
91	144.00	144.87
92	145.60	146.46
93	147.20	148.06

Z	OD	PD
94	148.80	149.65
95	150.40	151.24
96	152.00	152.83
97	153.55	154.42
98	155.15	156.02
99	156.75	157.61
100	158.35	159.20
101	159.95	160.79
102	161.55	162.38
103	163.10	163.97
104	164.70	165.57
105	166.30	167.16
106	167.90	168.75
107	169.50	170.34
108	171.10	171.94
109	172.65	173.53
110	174.25	175.12
111	175.85	176.71
112	177.45	178.30
113	179.05	179.84
114	180.65	181.49
115	182.23	183.08
116	183.82	184.67
117	185.42	186.26
118	187.01	187.86
119	188.61	189.45
120	190.21	191.04

規格 Specification – T10

mm

Type	P	A	B	C	W
T2.5	2.5	40°	1.3	0.7	1.0
T5	5	40°	2.3	1.2	1.8
T10	10	40°	4.5	2.5	3.5
T20	20	40°	8	5.0	6.5

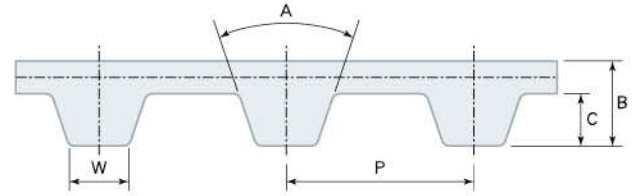

Z	OD	PD
10	30.05	31.84
11	33.25	35.02
12	36.35	38.20
13	39.50	41.38
14	42.70	44.56
15	45.90	47.75
16	49.05	50.93
17	52.25	54.11
18	55.45	57.29
19	58.65	60.48
20	61.80	63.66
21	65.00	66.84
22	68.15	70.03
23	71.35	73.20
24	74.55	76.39
25	77.70	79.58
26	80.90	82.76
27	84.10	85.95
28	87.25	89.12
29	90.45	92.21
30	93.65	95.49
31	96.85	98.67
32	100.00	101.86
33	103.20	105.04
34	106.40	108.22
35	109.55	111.41
36	112.75	114.59
37	115.90	117.77

Z	OD	PD
38	119.10	120.95
39	122.30	124.14
40	125.45	127.32
41	128.65	130.50
42	131.85	133.69
44	138.20	140.05
45	141.40	143.24
46	144.60	146.42
47	147.75	149.60
48	150.95	152.78
49	154.10	155.97
50	157.30	159.15
51	160.50	162.33
52	163.65	165.52
53	166.85	168.70
54	170.05	171.88
55	173.20	175.06
56	176.40	178.25
57	179.60	181.43
58	182.75	184.61
59	185.95	187.80
60	189.10	190.98
61	192.30	194.16
62	195.50	197.35
63	198.65	200.53
64	201.85	203.71
65	205.05	206.90
66	208.20	210.08

Z	OD	PD
67	211.40	213.26
68	214.60	216.44
69	217.75	219.63
70	220.95	222.81
71	224.15	225.99
72	227.30	229.18
73	230.50	232.36
74	233.70	235.54
75	236.90	238.72
76	240.05	241.94
77	243.25	245.09
78	246.40	248.27
79	249.60	251.46
80	252.80	254.64
81	256.00	257.82
82	259.15	261.00
83	262.30	264.19
84	265.50	267.37
85	268.70	270.55
86	271.90	273.74
87	275.05	276.92
88	278.25	280.10
89	281.45	283.28
90	284.60	286.47
91	287.80	289.65
92	291.00	292.84
93	294.20	296.02
94	297.35	299.20

Z	OD	PD
95	300.55	302.39
96	303.75	305.57
97	306.90	308.75
98	310.10	311.93
99	313.25	315.12
100	316.45	318.30
101	319.65	321.48
102	322.80	324.66
103	326.00	327.85
104	329.20	331.03
105	332.35	334.21
106	335.55	337.40
107	338.75	340.58
108	341.95	343.76
109	345.15	346.95
110	348.30	350.13
111	351.45	353.31
112	354.65	356.50
113	357.80	359.68
114	361.00	362.86
115	364.19	366.04
116	367.39	369.23
117	370.56	372.41
118	373.76	375.59
119	376.93	378.78
120	380.11	381.96

規格 Specification – T20

mm

Type	P	A	B	C	W
T2.5	2.5	40°	1.3	0.7	1.0
T5	5	40°	2.3	1.2	1.8
T10	10	40°	4.5	2.5	3.5
T20	20	40°	8	5.0	6.5

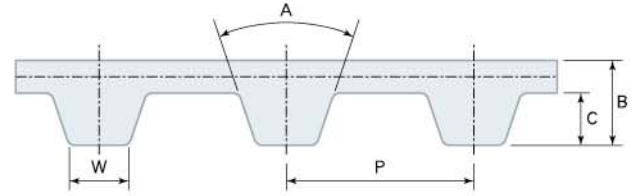

Z	OD	PD
15	92.65	95.49
16	99.00	101.86
17	105.40	108.22
18	111.75	114.59
19	118.10	120.96
20	124.50	127.32
21	130.75	133.69
22	137.20	140.06
23	143.55	146.43
24	149.95	152.78
25	156.30	159.15
26	162.65	165.52
27	169.00	171.89
28	175.40	178.25
29	181.75	184.62
30	188.10	190.99
31	194.50	197.35
32	200.85	203.72
33	207.20	210.09
34	213.60	216.44
35	219.95	222.81
36	226.35	229.18
37	232.70	235.54
38	239.05	241.91
39	245.40	248.28
40	251.75	254.65
41	258.15	261.02
42	264.50	267.37

Z	OD	PD
43	270.85	273.74
44	277.25	280.10
45	283.60	286.47
46	289.95	292.84
47	296.35	299.21
48	302.70	305.58
49	309.10	311.93
50	315.45	318.30
51	321.80	324.67
52	328.15	331.03
53	334.50	337.40
54	340.90	343.76
55	347.25	350.13
56	353.60	356.50
57	360.00	362.86
58	366.35	369.23
59	372.75	375.59
60	379.10	381.96
61	385.45	388.33
62	391.85	394.70
63	398.20	401.06
64	404.55	407.43
65	410.95	413.80
66	417.30	420.17
67	423.65	426.52
68	430.05	432.89
69	436.40	439.26
70	442.80	445.63

Z	OD	PD
71	449.15	451.99
72	455.50	458.36
73	461.85	464.73
74	468.25	471.08
75	474.60	477.45
76	480.95	483.82
77	487.35	490.19
78	493.70	496.56
79	500.05	502.91
80	506.45	509.28
81	512.80	515.65
82	519.15	522.02
83	525.55	528.39
84	531.90	534.74
85	538.25	541.11
86	544.60	547.48
87	551.00	553.85
88	557.35	560.22
89	563.70	566.57
90	570.10	572.94
91	576.45	579.31
92	582.85	585.67
93	589.20	592.04
94	595.55	598.41
95	601.90	604.77
96	608.30	611.14
97	614.65	617.51
98	621.00	623.88

Z	OD	PD
99	627.35	630.25
100	633.75	636.60
101	640.10	642.97
102	646.50	649.34
103	652.85	655.71
104	659.20	662.06
105	665.60	668.43
106	671.95	674.80
107	678.30	681.17
108	684.70	687.54
109	691.05	693.89
110	697.40	700.26
111	703.80	706.63
112	710.15	712.99
113	716.50	719.36
114	722.90	725.73
115	729.24	732.09
116	735.61	738.46
117	741.96	744.83
118	748.34	751.19
119	754.70	757.56
120	761.07	763.93

T20 T-Type

規格 Specification – AT3

mm

Type	P	A	B	C	W
AT3	3	50°	1.9	1.1	1.5
AT5	5	50°	2.7	1.2	2.5
AT10	10	50°	4.5	2.5	5.0
AT20	20	50°	8	5.0	10

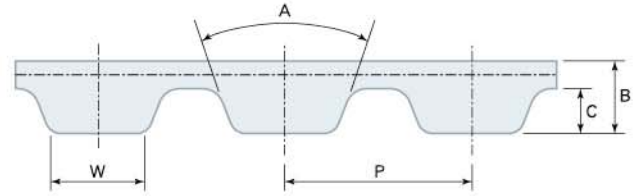

Z	OD	PD
15	13.92	14.32
16	14.87	15.28
17	15.82	16.23
18	16.78	17.19
19	17.73	18.14
20	18.69	19.10
21	19.64	20.05
22	20.60	21.01
23	21.55	21.96
24	22.51	22.92
25	23.46	23.87
26	24.42	24.83
27	25.37	25.78
28	26.33	26.74
29	27.28	27.69
30	28.24	28.65
31	29.19	29.60
32	30.15	30.56
33	31.10	31.51
34	32.06	32.47
35	33.01	33.42
36	33.97	34.38
37	34.92	35.33
38	35.88	36.29
39	36.83	37.24
40	37.79	38.20
41	38.74	39.15
42	39.70	40.11

Z	OD	PD
43	40.65	41.06
44	41.61	42.02
45	42.56	42.97
46	43.52	43.93
47	44.47	44.88
48	45.43	45.84
49	46.38	46.79
50	47.34	47.75
51	48.29	48.70
52	49.25	49.66
53	50.20	50.61
54	51.16	51.57
55	52.11	52.52
56	53.07	53.48
57	54.02	54.43
58	54.98	55.39
59	55.93	56.34
60	56.89	57.30
61	57.84	58.25
62	58.80	59.21
63	59.75	60.16
64	60.71	61.12
65	61.66	62.07
66	62.62	63.03
67	63.57	63.98
68	64.53	64.94
69	65.48	65.89
70	66.44	66.85

Z	OD	PD
71	67.39	67.80
72	68.35	68.75
73	69.30	69.71
74	70.25	70.66
75	71.21	71.62
76	72.16	72.57
77	73.12	73.53
78	74.07	74.48
79	75.03	75.44
80	75.98	76.39
81	76.94	77.35
82	77.89	78.30
83	78.85	79.26
84	79.80	80.21
85	80.76	81.17
86	81.71	82.12
87	82.67	83.08
88	83.62	84.03
89	84.58	84.99
90	85.53	85.94
91	86.49	86.90
92	87.44	87.85
93	88.40	88.81
94	89.35	89.76
95	90.31	90.72
96	91.26	91.67
97	92.22	92.63
98	93.17	93.58

Z	OD	PD
99	94.13	94.54
100	95.08	95.49
101	96.04	96.45
102	96.99	97.40
103	97.95	98.36
104	98.90	99.31
105	99.86	100.27
106	100.81	101.22
107	101.77	102.18
108	102.72	103.13
109	103.68	104.09
110	104.63	105.04
111	105.59	106.00
112	106.54	106.95
113	107.50	107.91
114	108.45	108.86

規格 Specification – AT5

mm

Type	P	A	B	C	W
AT3	3	50°	1.9	1.1	1.5
AT5	5	50°	2.7	1.2	2.5
AT10	10	50°	4.5	2.5	5.0
AT20	20	50°	8	5.0	10

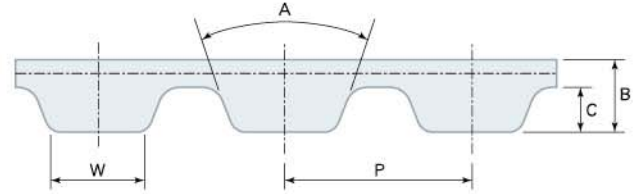

Z	OD	PD
15	22.65	23.88
16	24.20	25.47
17	25.80	27.06
18	27.40	28.65
19	29.00	30.25
20	30.60	31.83
21	32.20	33.43
22	33.80	35.02
23	35.40	36.62
24	37.00	38.21
25	38.60	39.80
26	40.20	41.39
27	41.80	42.98
28	43.35	44.58
29	44.95	46.17
30	46.55	47.76
31	48.15	49.35
32	49.70	50.94
33	51.30	52.54
34	52.85	54.13
35	54.45	55.72
36	56.05	57.31
37	57.65	58.90
38	59.25	60.50
39	60.85	62.09
40	62.45	63.66
41	64.00	65.27
42	65.60	66.86

Z	OD	PD
43	67.30	68.46
44	68.80	70.05
45	70.40	71.64
46	72.00	73.23
47	73.55	74.82
48	75.15	76.42
49	76.75	78.01
50	78.35	79.60
51	79.95	81.19
52	81.55	82.78
53	83.10	84.38
54	84.70	85.97
55	86.30	87.54
56	87.90	89.15
57	89.50	90.74
58	91.10	92.34
59	92.65	93.93
60	94.25	95.52
61	95.85	97.11
62	97.45	98.70
63	99.05	100.30
64	100.65	101.89
65	102.25	103.48
66	103.80	105.07
67	105.40	106.66
68	107.00	108.26
69	108.60	109.85
70	110.20	111.44

Z	OD	PD
71	111.80	113.03
72	113.35	114.62
73	114.95	116.22
74	116.55	117.81
75	118.15	119.40
76	119.75	120.99
77	121.35	122.58
78	122.90	124.18
79	124.50	125.77
80	126.10	127.36
81	127.70	128.95
82	129.30	130.54
83	130.90	132.14
84	132.45	133.73
85	134.05	135.32
86	135.65	136.91
87	137.25	138.50
88	138.85	140.10
89	140.45	141.69
90	142.05	143.28
91	143.60	144.87
92	145.20	146.46
93	146.80	148.06
94	148.40	149.65
95	150.00	151.24
96	151.60	152.83
97	153.15	154.42
98	154.75	156.02

Z	OD	PD
99	156.35	157.61
100	157.95	159.20
101	159.55	160.79
102	161.15	162.38
103	162.70	163.97
104	164.30	165.57
105	165.90	167.16
106	167.50	168.75
107	169.10	170.34
108	170.70	171.94
109	172.25	173.53
110	173.85	175.12
111	175.45	176.71
112	177.05	178.30
113	178.65	179.84
114	180.25	181.49
115	181.85	183.08
116	183.45	184.67
117	185.00	186.26
118	186.60	187.86
119	188.20	189.45
120	189.80	191.04

規格 Specification – AT10

mm

Type	P	A	B	C	W
AT3	3	50°	1.9	1.1	1.5
AT5	5	50°	2.7	1.2	2.5
AT10	10	50°	4.5	2.5	5.0
AT20	20	50°	8	5.0	10

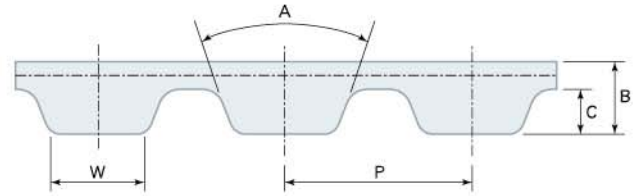

Z	OD	PD
15	45.70	47.75
16	49.05	50.93
17	52.25	54.11
18	55.45	57.29
19	58.60	60.48
20	61.80	63.66
21	65.00	66.84
22	68.15	70.03
23	71.35	73.20
24	74.55	76.39
25	77.70	79.58
26	80.90	82.76
27	84.10	85.95
28	87.25	89.12
29	90.45	92.21
30	93.65	95.49
31	96.80	98.67
32	100.00	101.86
33	103.20	105.04
34	106.40	108.19
35	109.55	111.41
36	112.75	114.59
37	115.90	117.77
38	119.10	120.95
39	122.30	124.14
40	125.45	127.32
41	128.65	130.50
42	131.85	133.69

Z	OD	PD
43	135.00	136.87
44	138.20	140.05
45	141.40	143.24
46	144.55	146.42
47	147.75	149.60
48	150.95	152.78
49	154.10	155.97
50	157.30	159.15
51	160.50	162.33
52	163.65	165.52
53	166.85	168.70
54	170.05	171.88
55	173.20	175.06
56	176.40	178.25
57	179.60	181.43
58	182.75	184.61
59	185.95	187.80
60	189.10	190.98
61	192.30	194.16
62	195.50	197.35
63	198.65	200.53
64	201.85	203.71
65	205.05	206.90
66	208.20	210.08
67	211.40	213.26
68	214.60	216.44
69	217.75	219.63
70	220.95	222.81

Z	OD	PD
71	224.15	225.99
72	227.30	229.18
73	230.50	232.33
74	233.70	235.54
75	236.90	238.72
76	240.05	241.94
77	243.25	245.09
78	246.40	248.24
79	249.60	251.46
80	252.80	254.64
81	255.95	257.82
82	259.15	261.00
83	262.30	264.19
84	265.50	267.37
85	268.70	270.52
86	271.90	273.74
87	275.05	276.92
88	278.25	280.10
89	281.45	283.28
90	284.60	286.47
91	287.80	289.65
92	291.00	292.84
93	294.20	296.02
94	297.35	299.20
95	300.55	302.39
96	303.70	305.57
97	306.90	308.75
98	310.10	311.93

Z	OD	PD
99	313.25	315.12
100	316.45	318.30
101	319.65	321.48
102	322.80	324.66
103	326.00	327.85
104	329.20	331.03
105	332.35	334.21
106	335.55	337.40
107	338.75	340.58
108	341.90	343.76
109	345.10	346.95
110	348.30	350.13
111	351.45	353.31
112	354.65	356.50
113	357.80	359.68
114	361.00	362.86
115	364.19	366.04
116	367.39	369.23
117	370.56	372.41
118	373.74	375.59
119	376.93	378.78
120	380.11	381.96

規格 Specification – AT20

mm

Type	P	A	B	C	W
AT3	3	50°	1.9	1.1	1.5
AT5	5	50°	2.7	1.2	2.5
AT10	10	50°	4.5	2.5	5.0
AT20	20	50°	8	5.0	10

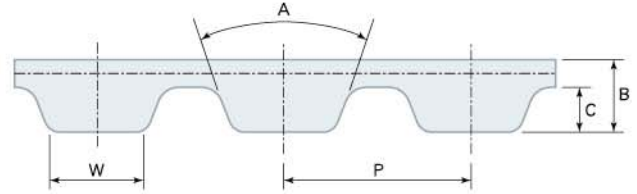

Z	OD	PD
18	111.75	114.59
19	118.10	120.95
20	124.50	127.32
21	130.75	133.69
22	137.20	140.05
23	143.55	146.42
24	149.95	152.78
25	156.30	159.15
26	162.65	165.52
27	169.05	171.88
28	175.40	178.25
29	181.75	184.62
30	188.15	190.99
31	194.50	197.35
32	200.85	203.72
33	207.20	210.09
34	213.60	216.44
35	219.95	222.81
36	226.35	229.18
37	232.70	235.54
38	239.05	241.91
39	245.45	248.27
40	251.80	254.64
41	258.15	261.01
42	264.50	267.37
43	270.90	273.74
44	277.25	280.10
45	283.60	286.47

Z	OD	PD
46	290.00	292.84
47	296.35	299.21
48	302.70	305.58
49	309.10	311.93
50	315.45	318.30
51	321.80	324.67
52	328.20	331.03
53	334.55	337.40
54	340.90	343.76
55	347.30	350.13
56	353.65	356.50
57	360.00	362.86
58	366.40	369.23
59	372.75	375.59
60	379.10	381.96
61	385.45	388.33
62	391.85	394.69
63	398.20	401.06
64	404.55	407.43
65	410.95	413.79
66	417.30	420.16
67	423.65	426.52
68	430.05	432.89
69	436.40	439.26
70	442.80	445.63
71	449.15	451.99
72	455.50	458.36
73	461.85	464.73

Z	OD	PD
74	468.25	471.08
75	474.60	477.45
76	480.95	483.82
77	487.35	490.19
78	493.70	496.56
79	500.05	502.91
80	506.45	509.28
81	512.80	515.65
82	519.15	522.02
83	525.55	528.39
84	531.90	534.74
85	538.25	541.11
86	544.60	547.48
87	551.00	553.85
88	557.35	560.22
89	563.70	566.57
90	570.10	572.94
91	576.45	579.31
92	582.85	585.67
93	589.20	592.04
94	595.55	598.40
95	601.90	604.77
96	608.30	611.14
97	614.65	617.50
98	621.00	623.87
99	627.35	630.24
100	633.75	636.60
101	640.10	642.97

Z	OD	PD
102	646.50	649.34
103	652.85	655.71
104	659.20	662.06
105	665.60	668.43
106	671.95	674.80
107	678.30	681.17
108	684.70	687.54
109	691.05	693.89
110	697.40	700.26
111	703.80	706.63
112	710.15	712.99
113	716.50	719.36
114	722.90	725.72
115	729.24	732.09
116	735.61	738.46
117	741.96	744.83
118	748.34	751.19
119	754.70	757.56
120	761.07	763.93

規格 Specification

HTD-Timing Pulleys

Type	P	B	C	T	R1	R2
3M	3	2.4	1.22	1.78	0.57	0.25
5M	5	3.8	2.06	3.05	1.49	0.43
8M	8	6	3.36	5.15	2.45	0.76
14M	14	10	6.02	9.4	4.5	1.25
20M	20	13.2	8.4	14	6.5	1.25

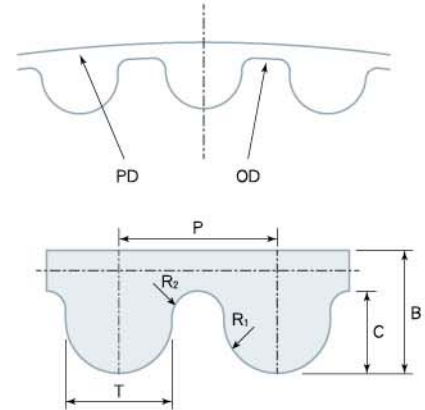

STD-Timing Pulleys

Type	P	B	C	T	R1	R2
3M	3	1.9	1.14	1.95	1.95	0.3
5M	5	3.4	1.91	3.25	3.25	0.5
8M	8	5.3	3.05	5.2	5.2	0.8
14M	14	10.2	5.3	9.1	9.1	1.4

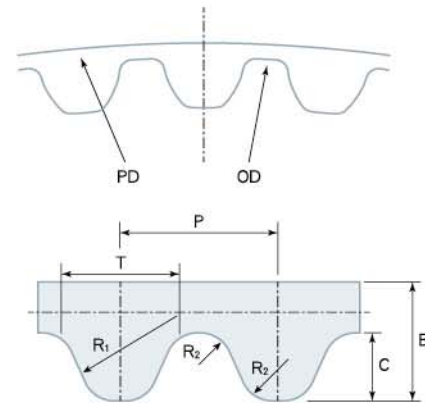

RPP-Timing Pulleys

Type	P	A	B	C	T	R1
3M	3	32°	1.9	1.15	1.95	0.4
5M	5	32°	3.5	1.95	3.3	0.6
8M	8	32°	5.5	3.2	5.5	1
14M	14	32°	10	6	9.5	1.75
20M	20	32°	13.2	8.4	14	2.1

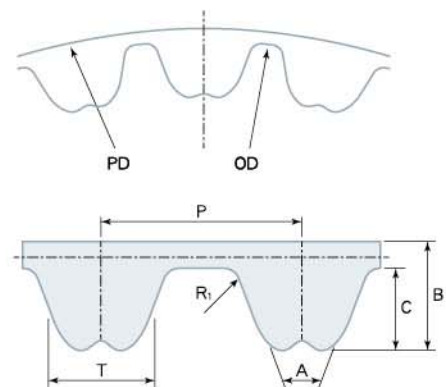

規格 Specification – 3M

Z	OD	PD	Z	OD	PD	Z	OD	PD	Z	OD	PD
10	8.79	9.55	49	46.03	46.79	87	82.32	83.08	125	118.61	119.37
12	10.70	11.46	50	46.99	47.75	88	83.27	84.03	126	119.56	120.32
13	11.65	12.41	51	47.94	48.70	89	84.23	84.99	127	120.52	121.28
14	12.61	13.37	52	48.90	49.66	90	85.18	85.94	128	121.47	122.23
15	13.56	14.32	53	49.85	50.61	91	86.14	86.90	129	122.43	123.19
16	14.52	15.28	54	50.81	51.57	92	87.09	87.85	130	123.38	124.14
17	15.47	16.23	55	51.76	52.52	93	88.05	88.81	131	124.34	125.10
18	16.43	17.19	56	52.72	53.48	94	89.00	89.76	132	125.29	126.05
19	17.38	18.14	57	53.67	54.43	95	89.96	90.72	133	126.25	127.01
20	18.34	19.10	58	54.63	55.39	96	90.91	91.67	134	127.20	127.96
21	19.29	20.05	59	55.58	56.34	97	91.87	92.63	135	128.16	128.92
22	20.25	21.01	60	56.54	57.30	98	92.82	93.58	136	129.11	129.87
23	21.20	21.96	61	57.49	58.25	99	93.78	94.54	137	130.07	130.83
24	22.16	22.92	62	58.45	59.21	100	94.73	95.49	138	131.02	131.78
25	23.11	23.87	63	59.40	60.16	101	95.69	96.45	139	131.98	132.74
26	24.07	24.83	64	60.36	61.12	102	96.64	97.40	140	132.93	133.69
27	25.02	25.78	65	61.31	62.07	103	97.60	98.36	141	133.89	134.65
28	25.98	26.74	66	62.27	63.03	104	98.55	99.31	142	134.84	135.60
29	26.93	27.69	67	63.22	63.98	105	99.51	100.27	143	135.79	136.55
30	27.89	28.65	68	64.18	64.94	106	100.46	101.22	144	136.75	137.51
31	28.84	29.60	69	65.13	65.89	107	101.42	102.18	145	137.70	138.46
32	29.80	30.56	70	66.09	66.85	108	102.37	103.13	146	138.66	139.42
33	30.75	31.51	71	67.04	67.80	109	103.33	104.09	147	139.61	140.37
34	31.71	32.47	72	67.99	68.75	110	104.28	105.04	148	140.57	141.33
35	32.66	33.42	73	68.95	69.71	111	105.24	106.00	149	141.52	142.28
36	33.62	34.38	74	69.90	70.66	112	106.19	106.95	150	142.48	143.24
37	34.57	35.33	75	70.86	71.62	113	107.15	107.91	151	143.43	144.19
38	35.53	36.29	76	71.81	72.57	114	108.10	108.86	152	144.39	145.15
39	36.48	37.24	77	72.77	73.53	115	109.06	109.82	153	145.34	146.10
40	37.44	38.20	78	73.72	74.48	116	110.01	110.77	154	146.30	147.06
41	38.39	39.15	79	74.68	75.44	117	110.97	111.73	155	147.25	148.01
42	39.35	40.11	80	75.63	76.39	118	111.92	112.68	156	148.21	148.97
43	40.30	41.06	81	76.59	77.35	119	112.88	113.64	157	149.16	149.92
44	41.26	42.02	82	77.54	78.30	120	113.83	114.59	158	150.12	150.88
45	42.21	42.97	83	78.50	79.26	121	114.79	115.55	159	151.07	151.83
46	43.17	43.93	84	79.45	80.21	122	115.74	116.50	160	152.03	152.79
47	44.12	44.88	85	80.41	81.17	123	116.70	117.46			
48	45.08	45.84	86	81.36	82.12	124	117.65	118.41			

3M HTD, STD, RPP-Type

規格 Specification – 5M

Z	OD	PD	Z	OD	PD	Z	OD	PD	Z	OD	PD
13	19.55	20.69	51	80.03	81.17	89	140.51	141.65	127	200.99	202.13
14	21.14	22.28	52	81.62	82.76	90	142.10	143.24	128	202.58	203.72
15	22.73	23.87	53	83.21	84.35	91	143.69	144.83	129	204.17	205.31
16	24.32	25.46	54	84.80	85.94	92	145.28	146.42	130	205.76	206.90
17	25.92	27.06	55	86.40	87.54	93	146.87	148.01	131	207.35	208.49
18	27.51	28.65	56	87.99	89.13	94	148.47	149.61	132	208.94	210.08
19	29.10	30.24	57	89.58	90.72	95	150.06	151.20	133	210.54	211.68
20	30.69	31.83	58	91.17	92.31	96	151.65	152.79	134	212.13	213.27
21	32.28	33.42	59	92.76	93.90	97	153.24	154.38	135	213.72	214.86
22	33.87	35.01	60	94.35	95.49	98	154.83	155.97	136	215.31	216.45
23	35.47	36.61	61	95.94	97.08	99	156.42	157.56	137	216.90	218.04
24	37.06	38.20	62	97.54	98.68	100	158.01	159.15	138	218.49	219.63
25	38.65	39.79	63	99.13	100.27	101	159.61	160.75	139	220.09	221.23
26	40.24	41.38	64	100.72	101.86	102	161.20	162.34	140	221.68	222.82
27	41.83	42.97	65	102.31	103.45	103	162.79	163.93	141	223.27	224.41
28	43.42	44.56	66	103.90	105.04	104	164.38	165.52	142	224.86	226.00
29	45.01	46.15	67	105.49	106.63	105	165.97	167.11	143	226.45	227.59
30	46.61	47.75	68	107.09	108.23	106	167.56	168.70	144	228.04	229.18
31	48.20	49.34	69	108.68	109.82	107	169.16	170.30	145	229.63	230.77
32	49.79	50.93	70	110.27	111.41	108	170.75	171.89	146	231.23	232.37
33	51.38	52.52	71	111.86	113.00	109	172.34	173.48	147	232.82	233.96
34	52.97	54.11	72	113.45	114.59	110	173.93	175.07	148	234.41	235.55
35	54.56	55.70	73	115.04	116.18	111	175.52	176.66	149	236.00	237.14
36	56.16	57.30	74	116.63	117.77	112	177.11	178.25	150	237.59	238.73
37	57.75	58.89	75	118.23	119.37	113	178.71	179.85	151	239.18	240.32
38	59.34	60.48	76	119.82	120.96	114	180.30	181.44	152	240.78	241.92
39	60.93	62.07	77	121.41	122.55	115	181.89	183.03	153	242.37	243.51
40	62.52	63.66	78	123.00	124.14	116	183.48	184.62	154	243.96	245.10
41	64.11	65.25	79	124.59	125.73	117	185.07	186.21	155	245.55	246.69
42	65.71	66.85	80	126.18	127.32	118	186.66	187.80	156	247.14	248.28
43	67.30	68.44	81	127.78	128.92	119	188.25	189.39	157	248.73	249.87
44	68.89	70.03	82	129.37	130.51	120	189.85	190.99	158	250.32	251.46
45	70.48	71.62	83	130.96	132.10	121	191.44	192.58	159	251.92	253.06
46	72.07	73.21	84	132.55	133.69	122	193.03	194.17	160	253.51	254.65
47	73.66	74.80	85	134.14	135.28	123	194.62	195.76			
48	75.25	76.39	86	135.73	136.87	124	196.21	197.35			
49	76.85	77.99	87	137.32	138.46	125	197.80	198.94			
50	78.44	79.58	88	138.92	140.06	126	199.40	200.54			

規格 Specification – 8M

Z	OD	PD	Z	OD	PD	Z	OD	PD	Z	OD	PD
22	54.66	56.02	65	164.15	165.52	108	273.65	275.02	151	383.15	384.52
23	57.20	58.57	66	166.70	168.07	109	276.19	277.57	152	385.70	387.06
24	59.74	61.12	67	169.24	170.61	110	278.74	280.11	153	388.24	389.61
25	62.28	63.66	68	171.79	173.16	111	281.29	282.66	154	390.79	392.16
26	64.85	66.21	69	174.34	175.71	112	283.83	285.21	155	393.33	394.70
27	67.39	68.75	70	176.88	178.25	113	286.38	287.75	156	395.88	397.25
28	70.08	71.30	71	179.43	180.80	114	288.93	290.30	157	398.43	399.80
29	72.62	73.85	72	181.97	183.35	115	291.47	292.84	158	400.97	402.34
30	75.13	76.39	73	184.52	185.89	116	294.02	295.39	159	403.52	404.89
31	77.65	78.94	74	187.07	188.44	117	296.57	297.94	160	406.07	407.44
32	80.16	81.49	75	189.61	190.99	118	299.11	300.48	161	408.61	409.98
33	82.68	84.03	76	192.16	193.53	119	301.66	303.03	162	411.16	412.53
34	85.22	86.58	77	194.71	196.08	120	304.21	305.58	163	413.70	415.08
35	87.76	89.13	78	197.25	198.63	121	306.75	308.12	164	416.25	417.62
36	90.30	91.67	79	199.81	201.17	122	309.30	310.67	165	418.80	420.17
37	92.85	94.22	80	202.35	203.72	123	311.85	313.22	166	421.34	422.72
38	95.39	96.77	81	204.89	206.26	124	314.39	315.76	167	423.89	425.26
39	97.94	99.31	82	207.44	208.81	125	316.94	318.31	168	426.44	427.81
40	100.49	101.86	83	209.99	211.36	126	319.48	320.86	169	428.98	430.35
41	103.03	104.41	84	212.53	213.90	127	322.03	323.40	170	431.53	432.90
42	105.58	106.95	85	215.08	216.45	128	324.58	325.95	171	434.08	435.45
43	108.13	109.50	86	217.63	219.00	129	327.12	328.50	172	436.62	437.99
44	110.67	112.05	87	220.17	221.54	130	329.67	331.04	173	439.17	440.54
45	113.22	114.59	88	222.72	224.09	131	332.22	333.59	174	441.72	443.09
46	115.77	117.14	89	225.27	226.64	132	334.76	336.14	175	444.26	445.63
47	118.31	119.68	90	227.81	229.18	133	337.31	338.68	176	446.81	448.18
48	120.86	122.23	91	230.36	231.73	134	339.86	341.23	177	449.36	450.73
49	123.41	124.78	92	232.90	234.28	135	342.40	343.77	178	451.90	453.27
50	125.95	127.32	93	235.45	236.82	136	344.95	346.32	179	454.45	455.82
51	128.50	129.87	94	238.00	239.37	137	347.50	348.87	180	456.99	458.37
52	131.05	132.42	95	240.54	241.92	138	350.04	351.41	181	459.54	460.91
53	133.59	134.96	96	243.09	244.46	139	352.59	353.96	182	462.09	463.46
54	136.14	137.51	97	245.64	247.01	140	355.14	356.51	183	464.63	466.01
55	138.68	140.06	98	248.18	249.55	141	357.68	359.05	184	467.18	468.55
56	141.23	142.60	99	250.73	252.10	142	360.23	361.60	185	469.73	471.10
57	143.78	145.15	100	253.28	254.65	143	362.77	364.15	186	472.27	473.64
58	146.32	147.70	101	255.82	257.19	144	365.32	366.69	187	474.82	476.19
59	148.87	150.24	102	258.37	259.74	145	367.87	369.24	188	477.37	478.74
60	151.42	152.79	103	260.92	262.29	146	370.41	371.79	189	479.91	481.28
61	153.96	155.34	104	263.46	264.83	147	372.96	374.33	190	482.46	483.83
62	156.51	157.88	105	266.01	267.38	148	375.51	376.88	191	485.01	486.38
63	159.06	160.43	106	268.56	269.93	149	378.05	379.43	192	487.55	488.92
64	161.60	162.97	107	271.10	272.47	150	380.60	381.97			

規格 Specification – 14M

Z	OD	PD	Z	OD	PD	Z	OD	PD	Z	OD	PD
28	122.12	124.78	76	335.89	338.68	124	549.79	552.59	172	763.70	766.49
29	126.57	129.23	77	340.34	343.14	125	554.25	557.04	173	768.15	770.95
30	130.99	133.69	78	344.80	347.59	126	558.70	561.50	174	772.61	775.40
31	135.46	138.15	79	349.26	352.05	127	563.16	565.95	175	777.06	779.86
32	139.88	142.60	80	353.71	356.51	128	567.62	570.41	176	781.52	784.32
33	144.35	147.06	81	358.17	360.96	129	572.07	574.87	177	785.98	788.77
34	148.79	151.52	82	362.63	365.42	130	576.53	579.32	178	790.43	793.23
35	153.24	155.97	83	367.08	369.88	131	580.99	583.78	179	794.89	797.68
36	157.68	160.43	84	371.54	374.33	132	585.44	588.24	180	799.35	802.14
37	162.13	164.88	85	375.99	378.79	133	589.90	592.69	181	803.80	806.60
38	166.60	169.34	86	380.45	383.24	134	594.35	597.15	182	808.26	811.05
39	171.02	173.80	87	384.91	387.70	135	598.81	601.61	183	812.72	815.51
40	175.49	178.25	88	389.36	392.16	136	603.27	606.06	184	817.17	819.97
41	179.92	182.71	89	393.82	396.61	137	607.72	610.52	185	821.63	824.42
42	184.37	187.17	90	398.28	401.07	138	612.18	614.97	186	826.08	828.88
43	188.83	191.62	91	402.73	405.53	139	616.64	619.43	187	830.54	833.33
44	193.28	196.08	92	407.19	409.98	140	621.09	623.89	188	835.00	837.79
45	197.74	200.53	93	411.64	414.44	141	625.55	628.34	189	839.45	842.25
46	202.20	204.99	94	416.10	418.90	142	630.01	632.80	190	843.91	846.70
47	206.65	209.45	95	420.56	423.35	143	634.46	637.26	191	848.37	851.16
48	211.11	213.90	96	425.01	427.81	144	638.92	641.71	192	852.82	855.62
49	215.57	218.36	97	429.47	432.26	145	643.37	646.17	193	857.28	860.07
50	220.02	222.82	98	433.93	436.72	146	647.83	650.62	194	861.75	864.53
51	224.48	227.27	99	438.38	441.18	147	652.29	655.08	195	866.44	868.98
52	228.94	231.73	100	442.84	445.63	148	656.74	659.54	196	870.64	873.44
53	233.39	236.19	101	447.30	450.09	149	661.20	663.99	197	875.11	877.90
54	237.85	240.64	102	451.75	454.55	150	665.66	668.45	198	879.55	882.35
55	242.30	245.10	103	456.21	459.00	151	670.11	672.91	199	884.02	886.81
56	246.76	249.55	104	460.66	463.46	152	674.57	677.36	200	888.47	891.27
57	251.22	254.01	105	465.12	467.92	153	679.03	681.82	201	892.94	895.72
58	255.67	258.47	106	469.58	472.37	154	683.49	686.28	202	897.38	900.18
59	260.13	262.92	107	474.03	476.83	155	687.94	690.73	203	901.85	904.64
60	264.59	267.38	108	478.49	481.28	156	692.39	695.19	204	906.30	909.09
61	269.04	271.84	109	482.95	485.74	157	696.85	699.64	205	910.74	913.55
62	273.50	276.29	110	487.40	490.20	158	701.31	704.10	206	915.21	918.00
63	277.95	280.75	111	491.86	494.65	159	705.76	708.56	207	919.66	922.46
64	282.41	285.21	112	496.32	499.11	160	710.22	713.01	208	924.13	926.92
65	286.87	289.66	113	500.77	503.57	161	714.68	717.47	209	928.57	931.37
66	291.32	294.12	114	505.23	508.02	162	719.13	721.93	210	933.04	935.83
67	295.78	298.57	115	509.68	512.48	163	723.59	726.38	211	937.49	940.29
68	300.24	303.03	116	514.14	516.93	164	728.05	730.84	212	941.96	944.74
69	304.69	307.49	117	518.60	521.39	165	732.50	735.30	213	946.40	949.20
70	309.15	311.94	118	523.05	525.85	166	736.96	739.75	214	950.85	953.65
71	313.61	316.40	119	527.51	530.30	167	741.41	744.21	215	955.32	958.11
72	318.06	320.86	120	531.97	534.76	168	745.87	748.66	216	959.76	962.57
73	322.52	325.31	121	536.42	539.22	169	750.33	753.12			
74	326.97	329.77	122	540.88	543.67	170	754.78	757.58			
75	331.43	334.22	123	545.34	548.13	171	759.24	762.03			

規格 Specification – 20M

Z	OD	PD	Z	OD	PD	Z	OD	PD	Z	OD	PD
34	212.13	216.45	80	504.98	509.30	126	797.82	805.14	172	1,090.67	1,094.99
35	218.50	222.82	81	511.34	515.66	127	804.19	808.51	173	1,097.03	1,101.35
36	224.87	229.18	82	517.71	522.03	128	810.56	814.87	174	1,103.40	1,107.72
37	231.23	235.55	83	524.08	528.39	129	816.92	821.24	175	1,109.77	1,114.08
38	237.60	241.92	84	530.44	534.76	130	823.29	827.61	176	1,116.13	1,120.45
39	243.96	248.28	85	536.81	541.13	131	829.65	833.97	177	1,122.50	1,126.82
40	250.33	254.65	86	543.18	547.49	132	836.02	840.34	178	1,128.87	1,133.18
41	256.70	261.01	87	549.54	553.86	133	842.39	846.70	179	1,135.23	1,139.55
42	263.06	267.38	88	555.91	560.23	134	848.75	853.07	180	1,141.60	1,145.92
43	269.43	273.75	89	562.27	566.59	135	855.12	859.44	181	1,147.96	1,152.28
44	275.79	280.11	90	568.64	572.96	136	861.48	865.80	182	1,154.33	1,158.65
45	282.16	286.48	91	575.01	579.32	137	867.85	872.17	183	1,160.70	1,165.01
46	288.53	292.85	92	581.37	585.69	138	874.22	878.54	184	1,167.06	1,171.38
47	294.89	299.21	93	587.74	592.06	139	880.58	884.90	185	1,173.43	1,177.75
48	301.26	305.58	94	594.10	598.42	140	886.95	891.27	186	1,179.79	1,184.11
49	307.63	311.94	95	600.47	604.72	141	893.32	897.63	187	1,186.16	1,190.48
50	313.99	318.31	96	606.84	611.15	142	899.68	904.00	188	1,192.53	1,196.85
51	320.36	324.68	97	613.20	617.52	143	906.05	910.37	189	1,198.89	1,203.21
52	326.72	331.04	98	619.57	623.89	144	912.41	916.73	190	1,205.26	1,209.58
53	333.09	337.41	99	625.94	630.25	145	918.78	923.10	191	1,211.63	1,215.94
54	339.46	343.77	100	632.30	636.62	146	925.15	929.46	192	1,217.99	1,222.31
55	345.82	350.14	101	638.67	642.99	147	931.51	935.83	193	1,224.36	1,228.68
56	352.19	356.51	102	645.03	649.35	148	937.88	942.20	194	1,230.72	1,235.04
57	358.56	362.87	103	651.40	655.72	149	944.25	948.56	195	1,237.09	1,241.41
58	364.92	369.24	104	657.77	662.08	150	950.61	954.93	196	1,243.46	1,247.77
59	371.29	375.61	105	664.13	668.45	151	956.98	961.30	197	1,249.82	1,254.14
60	377.65	381.97	106	670.50	674.82	152	963.34	967.66	198	1,256.19	1,260.51
61	384.02	388.34	107	676.87	681.18	153	969.71	974.03	199	1,262.56	1,266.87
62	390.39	394.70	108	683.23	687.55	154	976.08	980.39	200	1,268.92	1,273.24
63	396.75	401.07	109	689.60	693.92	155	982.44	986.76	201	1,275.29	1,279.61
64	403.12	407.44	110	695.96	700.28	156	988.81	993.13	202	1,281.65	1,285.97
65	409.48	413.80	111	702.33	706.65	157	995.18	999.49	203	1,288.02	1,292.34
66	415.85	420.17	112	708.70	713.01	158	1,001.54	1,005.86	204	1,294.39	1,298.70
67	422.22	426.54	113	715.06	719.38	159	1,007.91	1,012.23	205	1,300.75	1,305.07
68	428.58	432.90	114	721.43	725.75	160	1,014.27	1,018.59	206	1,307.12	1,311.44
69	434.95	439.27	115	727.79	732.11	161	1,020.64	1,024.96	207	1,313.48	1,317.80
70	441.32	445.63	116	734.16	738.48	162	1,027.01	1,031.32	208	1,319.85	1,324.17
71	447.68	452.00	117	740.53	744.85	163	1,033.37	1,037.69	209	1,326.22	1,330.54
72	454.05	458.37	118	746.89	751.21	164	1,039.74	1,044.06	210	1,332.58	1,336.90
73	460.41	464.73	119	753.26	757.58	165	1,046.10	1,050.42	211	1,338.95	1,343.27
74	466.78	471.10	120	759.63	763.94	166	1,052.47	1,056.79	212	1,345.32	1,349.63
75	473.15	477.46	121	765.99	770.31	167	1,058.84	1,063.16	213	1,351.68	1,356.00
76	479.51	483.83	122	772.36	776.68	168	1,065.20	1,069.52	214	1,358.05	1,362.37
77	485.88	490.20	123	778.72	783.04	169	1,071.57	1,075.89	215	1,364.41	1,368.73
78	492.25	496.56	124	785.09	789.41	170	1,077.94	1,082.25	216	1,370.79	1,375.10
79	498.61	502.93	125	791.46	795.77	171	1,084.30	1,088.62			

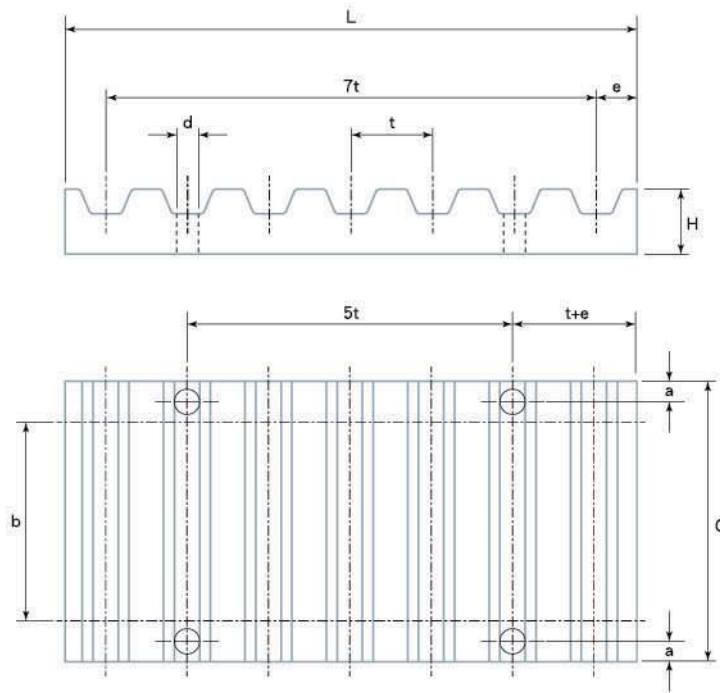

類型 Type	a [mm]	d [mm]	e [mm]	L [mm]	H [mm]	帶寬 Belt width [mm]							
						6	10	16	25	32	50	75	100
						C [mm]							
T5	6	5.5	3.2	41.8	8	-	29	35	44	-	-	-	-
AT5	6	5.5	3.2	41.8	8	-	29	35	44	-	-	-	-
T10	8	9	5	80	15	-	-	41	50	57	75	100	125
AT10	8	9	5	80	15	-	-	41	50	57	75	100	125
T20	10	11	10	160	20	-	-	-	56	63	81	106	132
AT20	10	11	10	160	20	-	-	-	56	63	81	106	132

類型 Type	a [mm]	d [mm]	e [mm]	L [mm]	H [mm]	帶寬 Belt width [英吋inch/100]							
						025	032	037	050	075	100	150	200
						C [mm]							
XL	6	5.5	3.5	42.5	8	25.5	27	28.5	-	-	-	-	-
L	8	9	6	76.6	15	-	-	36	39	45	51.5	64	77
H	10	11	9	106.9	22	-	-	-	45	51	57.5	70	83

HTD, STD, RPP

類型 Type	a [mm]	d [mm]	e [mm]	L [mm]	H [mm]	帶寬 Belt width [mm]								
						15	20	25	30	40	50	55	85	115
						C [mm]								
3M	5	4.5	2	25	5	21	24	30	-	-	-	-	-	-
5M	6	5.5	3.4	41.8	8	34	-	44	-	-	-	-	-	-
8M	8	9	5	66	15	40	45	-	55	-	75	-	110	-
14M	10	11	9	116	22	-	-	56	-	71	-	86	116	146